

UNIVERSITY OF CALIFORNIA BERKELEY
Department of Electrical Engineering and Computer Sciences

B. E. BOSER

The HP33120A Function Generator

EECS 100

The front panel of your function generator is shown in Figure 1. This instrument outputs a time-varying periodic voltage signal at the **OUTPUT** connector (do not use the sync connector; see Figure 2). The buttons on the front panel allow you to specify various characteristics of the signal.

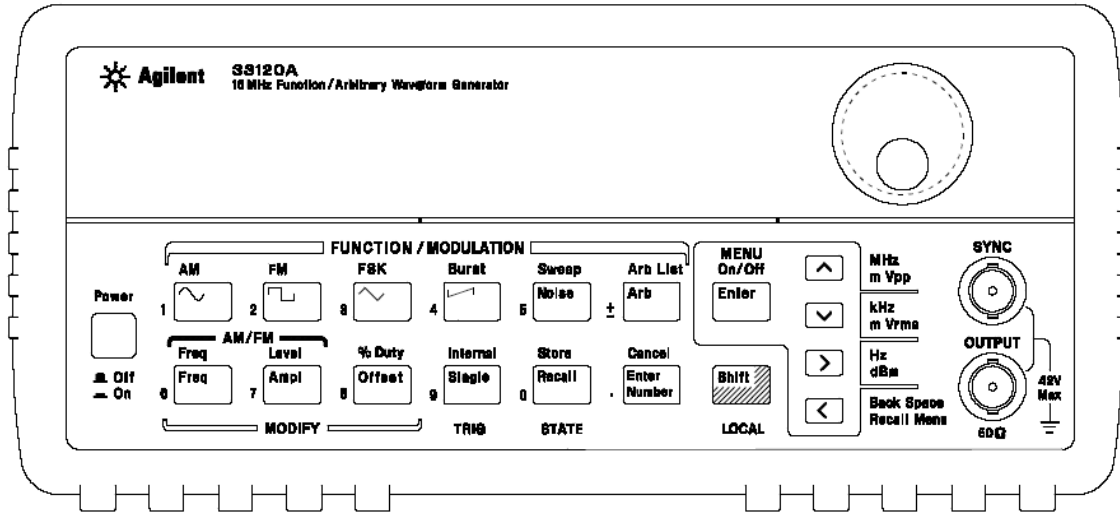

Figure 1. Front panel of your function generator
(Ref: Agilent Function Generator User's Guide #33120-90006)



Figure 2. Make sure you use **BLACK** BNC input cables. Connect them to the OUTPUT terminal as shown above. Do not use the SYNC connector

The main characteristics that you will be concerned with in this class are:

- **Shape:** sine, square, or triangle waves.
- **Frequency:** inverse of the signal period; units are cycles per second (Hz)
- **V_{pp} :** peak to peak voltage of the signal
- **DC Offset:** constant voltage added to the signal to increase or decrease its mean or average level. In a schematic, this would be a DC voltage source in series with the oscillating voltage source.

Figure 3 below illustrates a couple of these parameters.

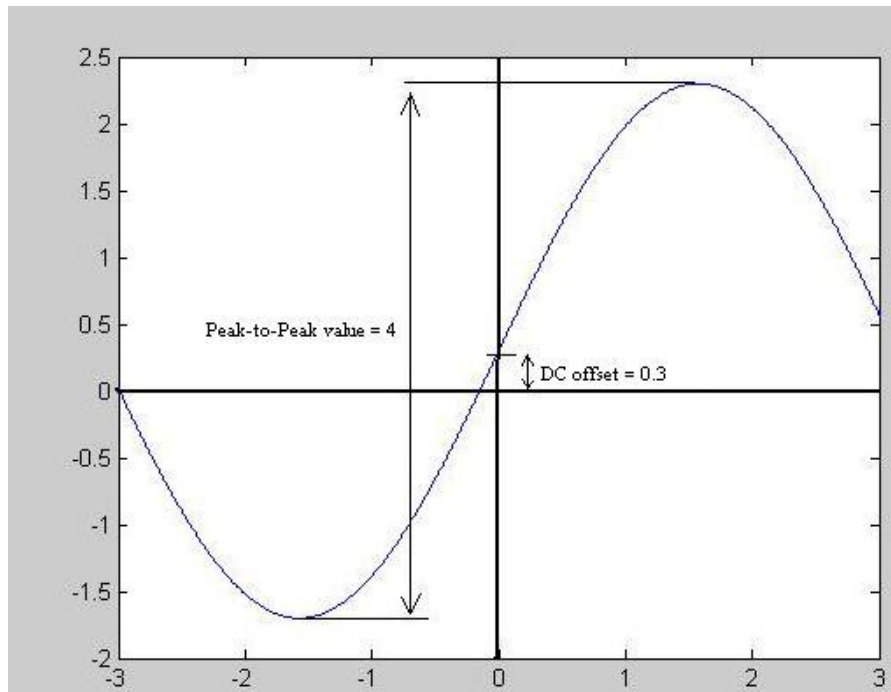

Figure 3. Sine wave V_{pp} and DC offset

By default when the function generator is turned on it outputs a sine wave at 1 kHz with amplitude of 100 mV_{PP} (Figure 4).



Figure 4. Function generator has been turned on

To modify the frequency of the signal, press the **Freq** button to enter the frequency modify mode.

Once in this mode, there are a few ways to edit the frequency.

1. Press the **Enter Number** button and enter the appropriate numbers on the pads labeled with the green numbers, and finally select the units to use.
2. Use the wheel and the up/down/right/left keypad buttons to change individual digits of the value. Right/left move from one digit place to another, while the up/down keys and the wheel will change the value of the digit that is selected.
3. Lastly, if you shift the cursor all the way to the right, you can use the wheel and up/down buttons to edit the units you are using for the output wave.

Try to generate a 15 Hz sinusoidal waveform with $V_{pp} = 1V$. Verify with the oscilloscope.

You can use the same procedure to modify the voltage of the output signal by first pressing the **Ampl** button to enter voltage modify mode.

IMPORTANT NOTE: The function generator has an internal 50Ω resistor in series with the oscillating voltage source as shown by the schematic in Figure 5.

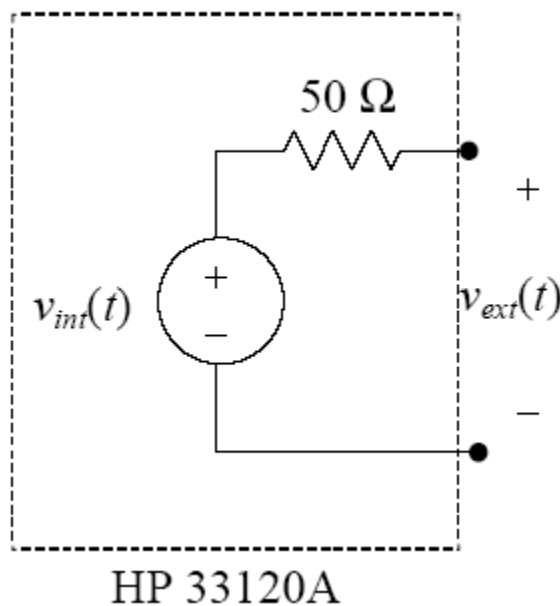

Figure 5. The internal load resistor in your function generator

Thus, if you connect the function generator to an external resistor R_L , it will form a voltage divider with the 50Ω resistor as illustrated in Figure 6.

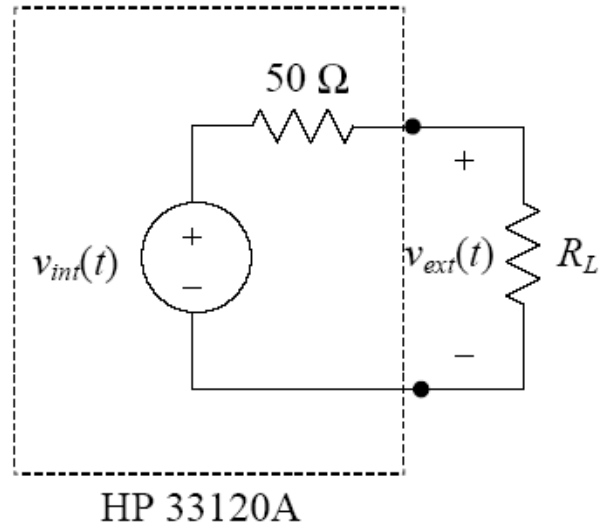

Figure 6. External resistor forming a voltage divider

Hence the voltage seen at the output of the instrument is:

$$v_{ext}(t) = \frac{R_L}{R_L + 50\Omega} \cdot v_{int}(t).$$

The purpose of the internal resistance is to have impedance matching (especially important for high frequency circuits) to maximize the power transferred, allowing circuits to work together and be cascaded and combined into larger circuits. In RF electronics, resistances of 50Ω are very common. For $R_L = 50\Omega$, we have:

$$v_{ext}(t) = \frac{1}{2} v_{int}(t).$$

The front panel meter assumes $R_L = 50\Omega$. As we saw above, a 50Ω load leads to a voltage divider with a gain of 1/2, so the instrument compensates for this by raising v_{int} to twice what the display shows. In other words, if you set the instrument to generate a 5 V sine wave, it actually produces a 10 V sine wave on v_{int} and relies on the voltage divider to reduce the signal amplitude by a factor of two to match the value displayed by the meter. We are not going to change the default setting of this instrument, so **remember that for $R_L = \infty$ (in practice, $R_L \gg 50\Omega$) you are getting twice the voltage displayed on the function generator at the output terminal.** It's always a good idea (and often a time saver) to check the actual waveform produced with the oscilloscope.